



Kigfast Limited



PRODUCT CATALOGUE





OUR PRODUCTS

Can't find a fastener with an unusual head or perhaps thread length.
Kigfast can supply fasteners and special bolting solutions.

We can supply bar turned and hot forged bolting on a normal or short lead time including emergency breakdowns. We have no minimum, even if its one-off that is required.

The Products we supply include bespoke fasteners as per our customer's drawings, reduced shank bolts, socket screws, cap nuts, studs, studbolts, tie bars in accordance with BS, DIN, ISO, ANSI standards.

Marking can be carried out to the requirements (size permitting).

The materials - as an example our fasteners are supplied in -

Carbon Steel

Alloy Steel ASTM, A193 B5, B6, B7, B7M, B16, EN16T, EN24T, EN26T

Stainless Steel 303, 304, 316/A480, 316L, 310, 321, 410, 431, ASTM, A193, B8, B8M, Class 1 and 2.

660 Precipitation Hardening Stainless Steel

Non Ferrous Materials

Duplex, UNS 31803, 32550, 32760, 31254

Aircraft Materials

Nickel Alloys - Alloy 20, 22, C276, 400, K500, 60



Various grades of Titanium.

Kigfast can also provide Zinc plating, hot dip galvanizing, sherardizing, and Xylan/PTFE coating. We can arrange for heat treatment and non-destructive testing to be provided locally

We can enamel coat any size head in any RAL or match any colour

We also have a range of Self Drilling screws, holding Down Bolts, with Cones Plates and Washers, Set Nut Washers in 8.8 Assembled and any type of Screws and Fixings for the Agricultural and industrial building Industry, including foamfillers, tapes, Masrtic, Fire Foam, painted head screws, moulded and hex head self drilling screws for cladding.

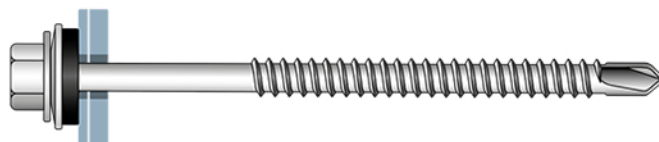



Kigfast Limited



KIG COLOUR

KIG
COLOUR



ENAMEL PAINTING

Powder coating is a modern, more environmentally-friendly alternative to traditional wet painting. Minute powder particles are applied to a metal object or component using an electrostatic spray process, which causes the powder to adhere to the metal surface. After spraying, the component is cured in an oven at up to 200°C. This process then melts the powder onto the metal creating a highly finished and durable coating. The finished product is very pleasing and is less prone to chipping. The powder coating process is faster than traditional wet painting where the product must dry between coats. With powder coating, the product is oven baked, so there is no need to wait for drying.

THE FOLLOWING OPTIONAL COATING CAN BE APPLIED

IRON PHOSPHATE (RAL COLOURS / TEXTURES)

Our Iron Phosphate process is an inline pre-process using Chemtelle Gardbond A4917 chemical. We also carry a comprehensive stock of RAL and BS colours. See our colour ref page.

FASTENER COATINGS

Jigs are available to fit most sizes of fasteners and rivets, to powder coat heads in many colours. We can colour-match any colour, mainly for the construction industry.

ANTI-RADAR COATINGS

We can locate M.O.D colours in powder for components up to 1,500mm x 1,000mm x 550mm with an iron phosphate pre-treatment.

ANTI-MICROBIAL COATINGS

We can locate anti-microbial powders in various colours, textured with pre-treatment of iron phosphate

FIRE-RETARDANT COATING

Low smoke and fume powder can be supplied to fulfil customer needs, with an iron-phosphate pre-treatment for railway contracts.



Carbon Steel Hex Head for 1.2mm - 3.5mm purlins

SCALE: 1:1

20.2 25.2 32.2 38.2 50.2 70.2 82.2 25.2LF

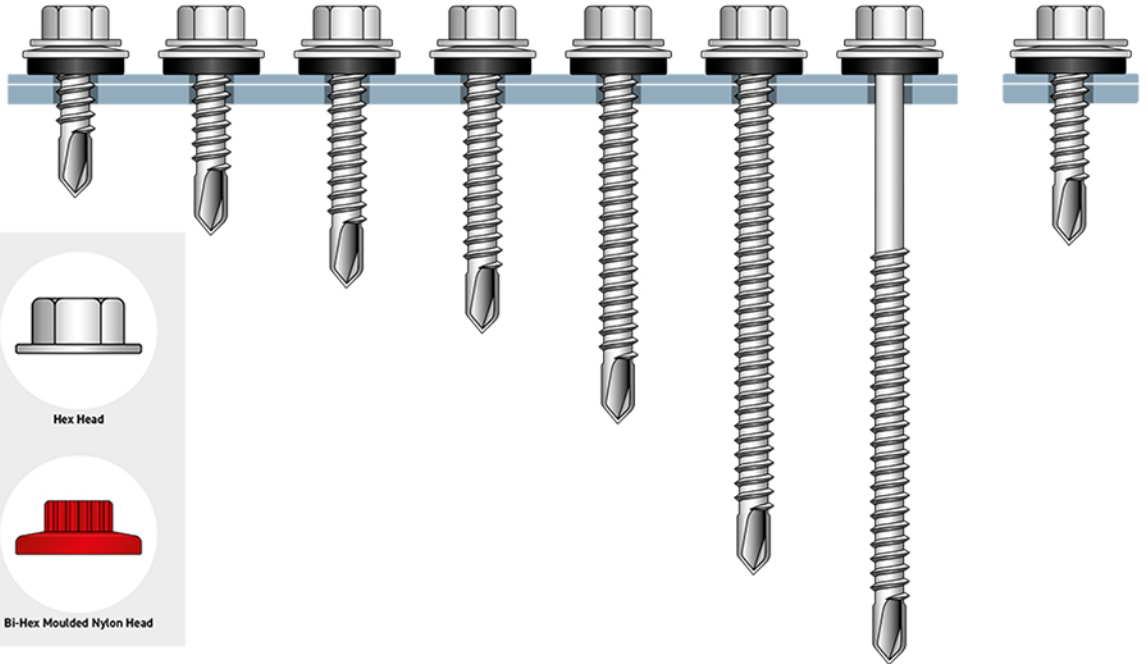

Stainless Steel Hex Head for 1.2mm - 3.5mm purlins / 1.5mm - 6mm

20.2SS 25.2SS 28.2SS 38.2SS 50.2SS 60.2SS 80.2SS 25.3SS 38.3SS

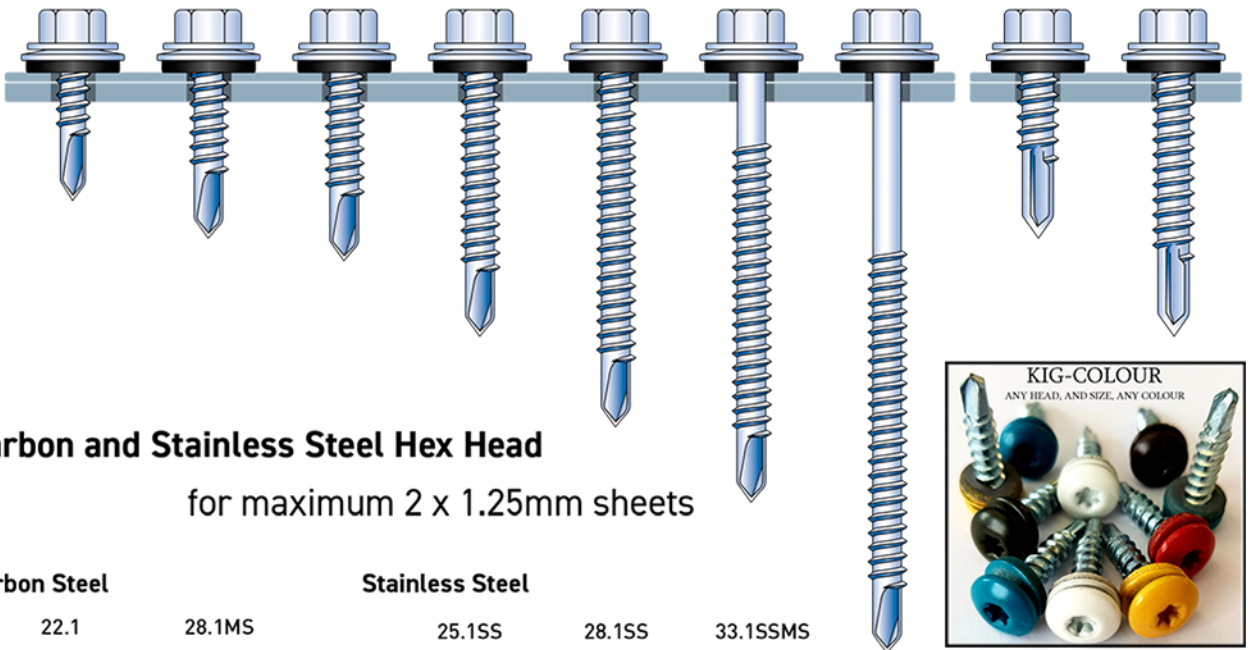

Carbon and Stainless Steel Hex Head for maximum 2 x 1.25mm sheets

Carbon Steel

Stainless Steel

22.1 28.1MS 25.1SS 28.1SS 33.1SSMS

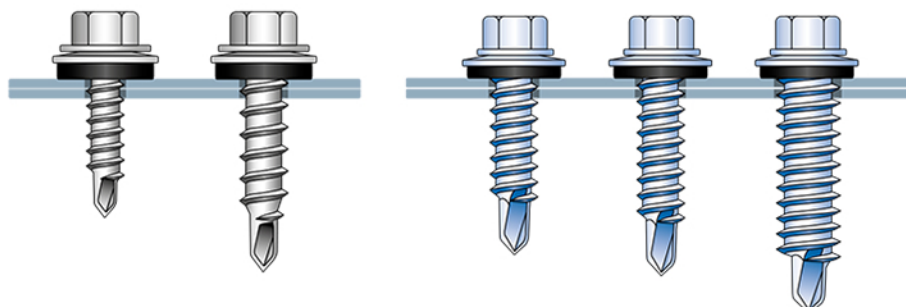

All Available
With low profile Heads
Painted



Kigfast Limited



Fibre cement Fixings & hook bolts

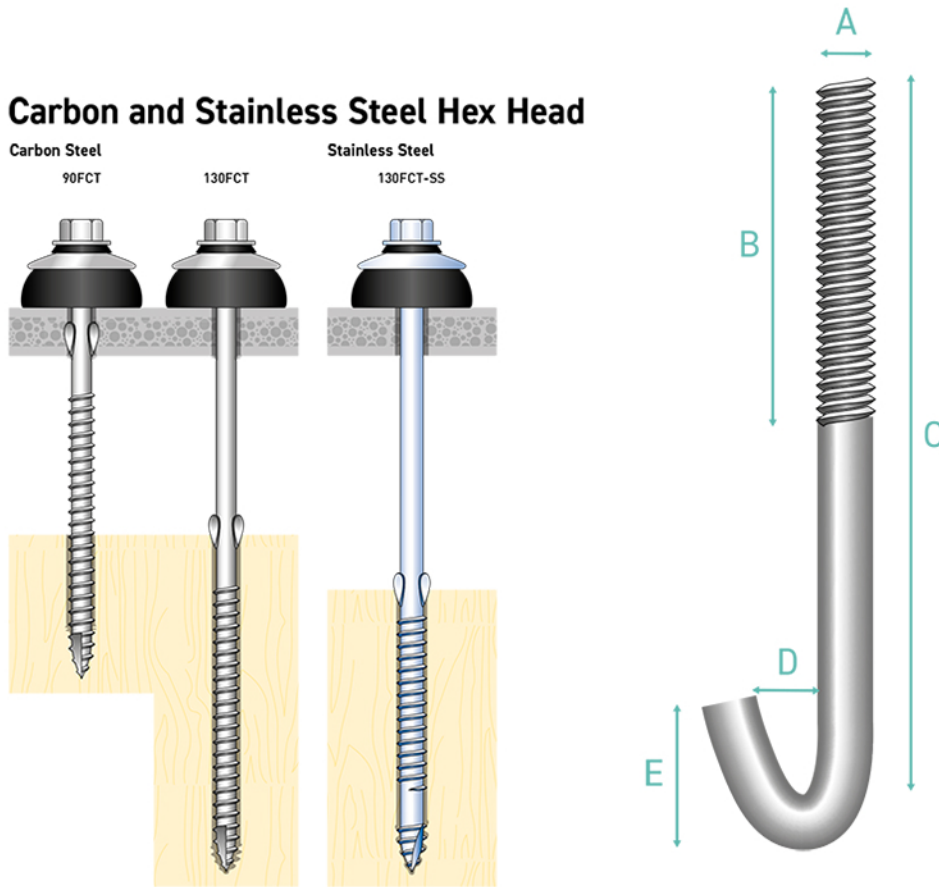

Hook Bolts are used in the roofing industry for fixing cladding and roofing panels to steel frames. These bolts are ideal for roofing as the hook side is not required to be accessed when the fastener is being tightened.

PART NUMBER	MATERIAL	FINISH	A (MM)	B (MM)	C (MM)	D (MM)	E (MM)
HOOKBOLT-M6X60	MILD STEEL	ZINC & YELLOW	6	50	60	15	22
HOOKBOLT-M6X80	MILD STEEL	ZINC & YELLOW	6	50	80	15	22
HOOKBOLT-M6X100	MILD STEEL	ZINC & YELLOW	6	50	100	15	22
HOOKBOLT-M6X160	MILD STEEL	ZINC & YELLOW	6	50	160	15	22
HOOKBOLT-M8X80	MILD STEEL	ZINC & YELLOW	8	50	80	15	22
HOOKBOLT-M8X100	MILD STEEL	ZINC & YELLOW	8	50	100	15	22
HOOKBOLT-M8X110	MILD STEEL	ZINC & YELLOW	8	50	110	15	22
HOOKBOLT-M8X120	MILD STEEL	ZINC & YELLOW	8	50	120	15	22
HOOKBOLT-M8X130	MILD STEEL	ZINC & YELLOW	8	50	130	15	22
HOOKBOLT-M8X140	MILD STEEL	ZINC & YELLOW	8	50	140	15	22
HOOKBOLT-M8X150	MILD STEEL	ZINC & YELLOW	8	50	150	15	22
HOOKBOLT-M8X160	MILD STEEL	ZINC & YELLOW	8	50	160	15	22
HOOKBOLT-M8X170	MILD STEEL	ZINC & YELLOW	8	50	170	15	22
HOOKBOLT-M8X180	MILD STEEL	ZINC & YELLOW	8	50	180	15	22
HOOKBOLT-M8X200	MILD STEEL	ZINC & YELLOW	8	50	200	15	22
HOOKBOLT-M8X220	MILD STEEL	ZINC & YELLOW	8	50	220	15	22
HOOKBOLT-M8X240	MILD STEEL	ZINC & YELLOW	8	50	240	15	22
HOOKBOLT-M8X260	MILD STEEL	ZINC & YELLOW	8	50	260	15	22



Composite Panel Fixings

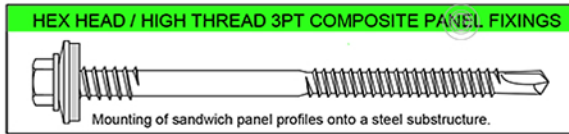
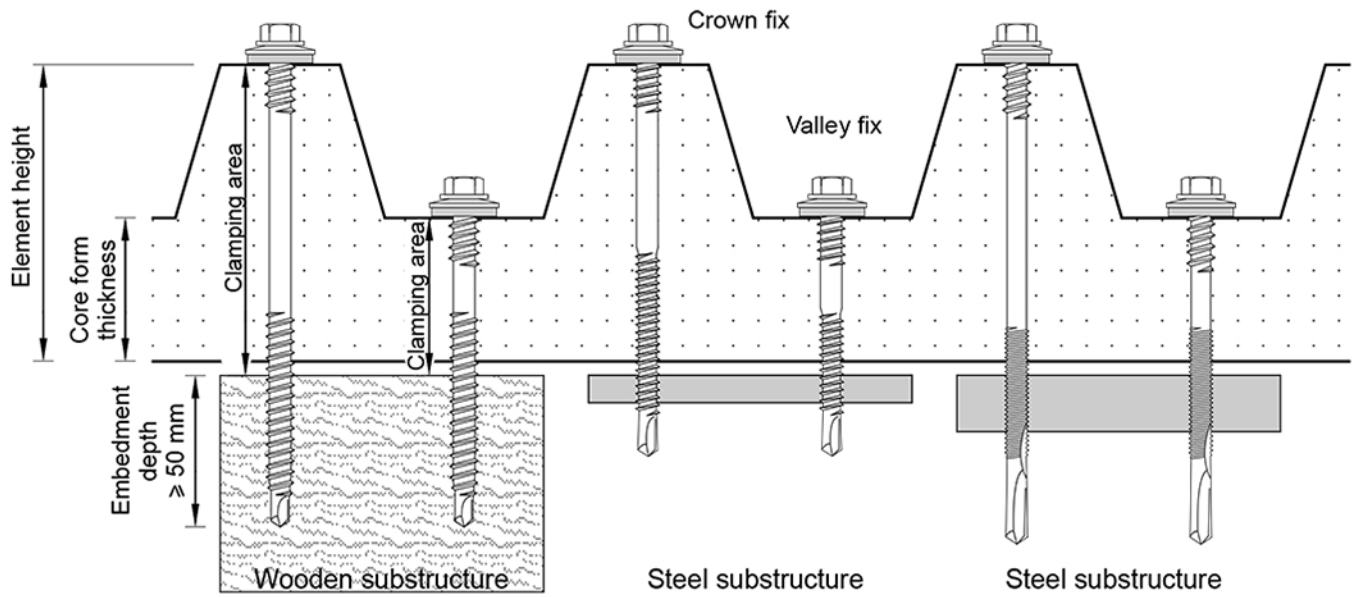

60HT/G16	25 - 40mm
65HT/G16	25 - 45mm
85HT/G16	40 - 60mm
98HT/G16	50 - 78mm
120HT/G16	60 - 100mm
130HT/G16	70 - 110mm
150HT/G16	70 - 130mm
180HT/G16	100 - 160mm
200HT/G16	120 - 180mm
230HT/G16	150 - 210mm

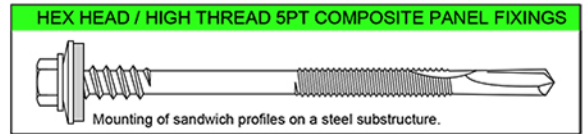

75HTL/G16	25 - 35mm
85HTL/G16	38 - 46mm
105HTL/G16	38 - 64mm
130HTL/G16	61 - 90mm
140HTL/G16	71 - 100mm
150HTL/G16	61 - 110mm
160HTL/G16	70 - 120mm
175HTL/G16	85 - 135mm
190HTL/G16	100 - 150mm
210HTL/G16	130 - 180mm
240HTL/G16	152 - 200mm
285HTL/G16	200 - 285mm



CARBON STEEL

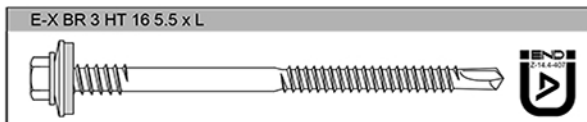

70HTSS/S16	17 - 47mm
85HTSS/S16	32 - 62mm
95HTSS/S16	42 - 72mm
110HTSS/S16	57 - 87mm
130HTSS/S16	57 - 107mm
150HTSS/S16	77 - 127mm
165HTSS/S16	92 - 142mm
180HTSS/S16	97 - 157mm
200HTSS/S16	117 - 177mm
230HTSS/S16	147 - 207mm
250HTSS/S16	167 - 227mm



STAINLESS STEEL

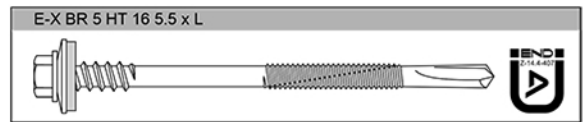

75HTLSS/S16	28 - 35mm
95HTLSS/S16	33 - 55mm
110HTLSS/S16	43 - 70mm
125HTLSS/S16	58 - 85mm
150HTLSS/S16	83 - 110mm
165HTLSS/S16	88 - 125mm
190HTLSS/S16	108 - 145mm
210HTLSS/S16	128 - 170mm
240HTLSS/S16	158 - 200mm
270HTLSS/S16	188 - 230mm
290HTLSS/S16	208 - 250mm



Kigfast Limited



Colours, Rivets & Caps

16mm & 19mm
Colour caps
For Hex head
Self Drilling Screws



Painted Alu Rivets

- MAIN COLOURS
 WHITE
 MUSHROOM
 BAMBOO
 VAN DYKE BROWN
 BLACK
 WEDGEWOOD BLUE
 OLIVE GREEN
 GOOSEWING GREY
 MOORLAND GREEN
 TERRACOTTA RED
 OCEAN BLUE
 MERLIN GREY
 JADE
 PETRA
 ACORN BROWN
 SVELTE GREY
 GLEN GREEN
 BURNT ORANGE
 POPPY RED
 TANGERINE ORANGE
 SAFFRON
 AZTEC YELLOW
 LINDEN GREEN
 DIHON MUSTARD
 VERONA GREEN
 SOLENT BLUE
 EAU DE NIL
 OYSTER
 METALLIC SILVER
 HONESTY
 MEADOWLANDS
 ALBATROS HAMLET
 BRITANNIA
 HERITAGE
 PINWOOD
 BURANO
 SARGASSO
 MOUNTAIN BLUE
 ALASKA GREY
 SLATE GREY
 HAHAMA BLUE
 SLATE BLUE
 JUNIPER GREEN
 ANY CHOSEN RAL:



Painted Low Profile



Painted Hex head



Painted Bolts

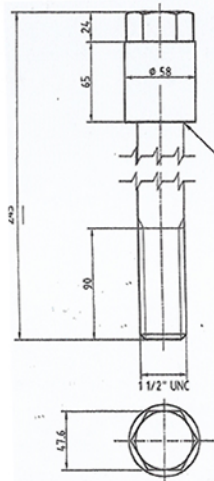

The Products we supply include bespoke fasteners as per our customer's drawings, reduced shank bolts, socket screws, cap nuts, studs, studbolts and tie bars in accordance with BS, DIN, ISO, ANSI standards.

Marking can be carried out to the requirements of the customer

COLOURS, RIVETS & CAPS



SUPERTEK7 RANGE DRILLING CAPACITY 4.0 - 18.0mm HOT ROLLED STEEL

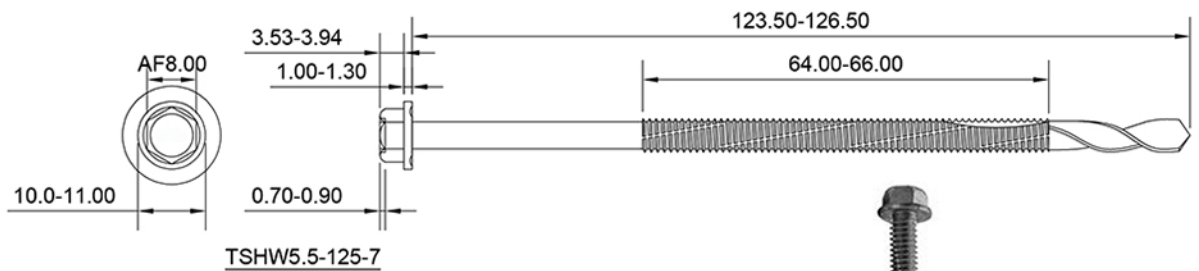
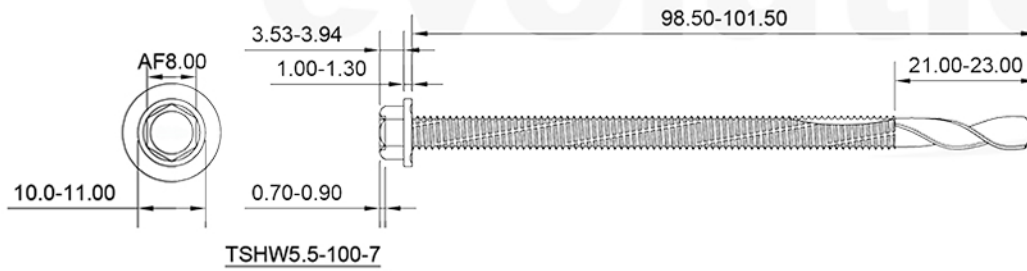
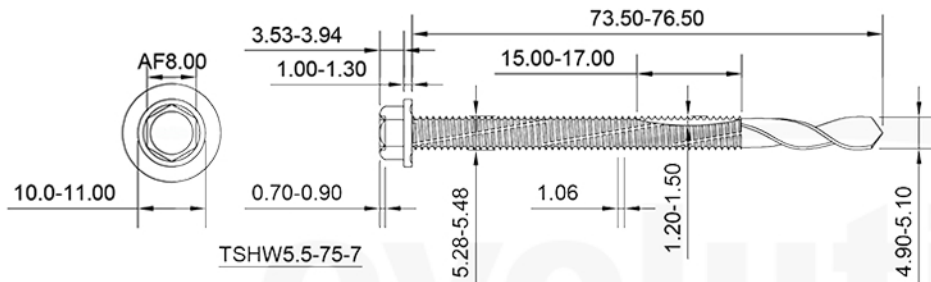
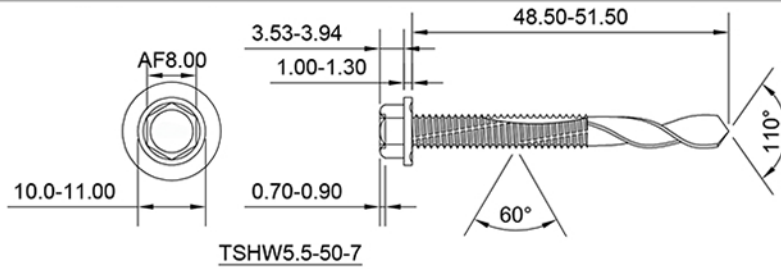

SUPERTEK7 RANGE PRODUCT DETAILS

Purpose:	Fixing steel to steel
Head style:	5/16" Hexagonal Head
Drill Point:	TEK 7 spiral point
Thread Form:	Single, 24 threads per inch fine thread 'V' fluted
Coating:	1000hr Rated EvoShield® Coating
Shank Material:	Carbon Steel
Material Grade:	AISI C1022
Recommended Drill Speed:	1,500 - 2,500 RPM

SKU	Nominal Dimensions, dnom x Lnom (mm)	Effective Thread Length, Lthread (mm)	Drilling Point	Drilling Capacity, Hcap (mm)
TSHW5.5-50-7	5.5 x 50.0	Full	TEK 7 Spiral Point	4.0 - 18.5
TSHW5.5-75-7	5.5 x 75.0	Full	TEK 7 Spiral Point	4.0 - 18.5
TSHW5.5-100-7	5.5 x 100.0	Full	TEK 7 Spiral Point	4.0 - 18.5
TSHW5.5-125-7	5.5 x 125.0	85.0	TEK 7 Spiral Point	4.0 - 18.5
TSHW5.5-150-7	5.5 x 150.0	85.0	TEK 7 Spiral Point	4.0 - 18.5



Kigfast Limited



Carbon Steel Hex Head

Concrete Screws

SCALE: 1:2

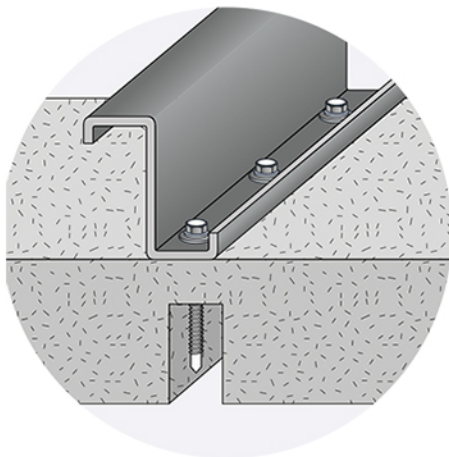
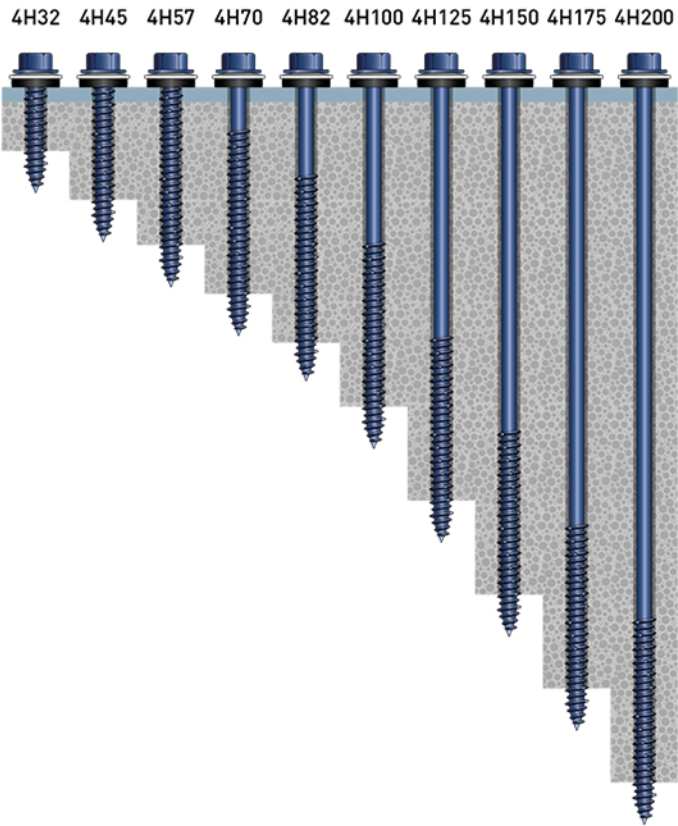

STANDARD 500+ COATING



STANDARD 5/16" HEAD



OPTIONAL BI-HEX HEAD



OPTIONAL POWDER COATED HEAD*



OPTIONAL WASHERS: 16MM, 19MM, 29MM

PART NUMBER	LENGTH (MM)	DIAMETER (MM)
4H32	32	6.35
4H45	45	6.35
4H57	57	6.35
4H70	70	6.35
4H82	82	6.35
4H100	100	6.35
4H125	125	6.35
4H150	150	6.35
4H175	175	6.35
4H200	200	6.35

CONCRETE SCREWS

Carbon Steel

SCALE: 1:2

Stainless Steel

SCALE: 1:1

38.3T 50.3T 60.3T 80.3T 100.3T 120.3T 150.3T 175.3T 200.3T

45.3SST 65.3SST

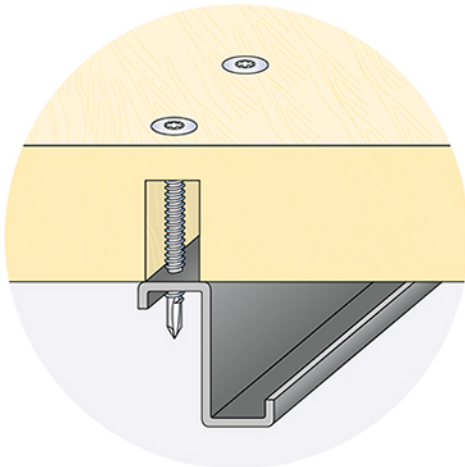
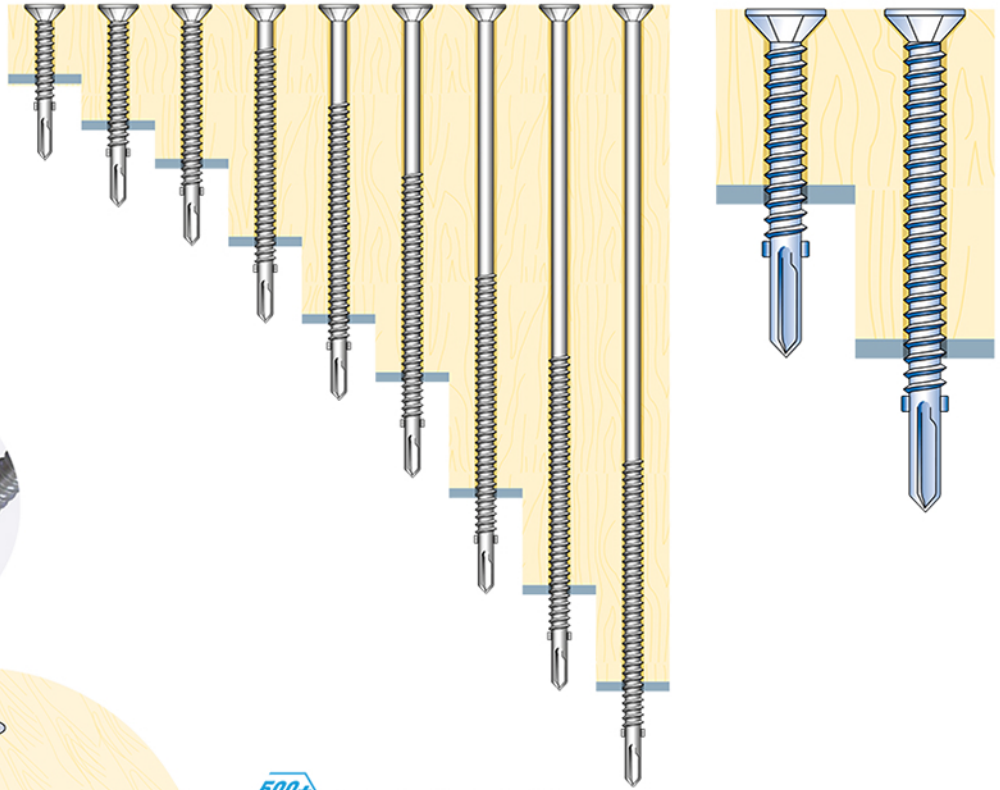

STANDARD 500+ COATING



STANDARD COUNTERSUNK HEAD



OPTIONAL POWDER COATED HEAD

Carbon Steel

PART NUMBER	LENGTH (MM)	DIAMETER (MM)	DRILL POINT	MIN TIMBER THICKNESS (MM)	MAX TIMBER THICKNESS (MM)
38.3T	38	4.8	No. 3	10	21
50.3T	50	5.5	No. 3	15	35
60.3T	60	5.5	No. 3	30	45
80.3T	80	5.5	No. 3	25	60
100.3T	100	5.5	No. 3	30	80
120.3T	120	5.5	No. 3	35	95
150.3T	150	5.5	No. 3	65	125
175.3T	175	5.5	No. 3	95	150
200.3T	200	5.5	No. 3	120	175

Stainless Steel

PART NUMBER	LENGTH (MM)	DIAMETER (MM)	DRILL POINT
45.3SST	45	4.8	No. 3
65.3SST	65	5.5	No. 3



Kigfast Limited



Standard Bolts and Nuts



STANDARD BOLTS AND NUTS



4.6 And 8.8 Holding Down Bolts c/w Cones Plates & Washers stocked

Examples

Anchor Bolts
 Blind Bolts
 Carriage Bolts
 Double End Bolts
 Eye Bolts
 Flange Bolts
 Hex Bolts
 Machine Bolts
 Machine Screws
 Round Head Bolts

Shoulder Bolts
 Socket Head Bolts
 Square Head Bolts
 T-Head Bolts
 U-Bolts
 Socket Cap Head Bolts
 Socket Csk Bolts
 Sets
 Allthread
 Studs

Through bolts
 Chemical Anchors
 Nuts, Nylocs,
 Lindaptors
 Washers
 Plates
 Rods
 Grub Screws
 Channel Bolts
 And Many more

 **Kigfast Limited** 

Unit 29
Spring Road Ind Estate
Lanesfield Drive
Wolverhampton
WV4 6UB

01902296444
www.kigfast.co.uk
sales@kigfast.co.uk

